

# DIMENSIONAL CONSIDERATIONS FOR Aluminum Hard Anodized Coatings

Because most of our work is critical tolerance, a number of dimensional factors must be considered in order to achieve the desired end-result.

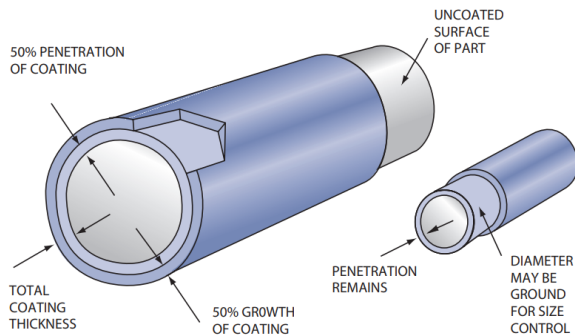

**ANODIZED THICKNESS (THE 50/50 RULE)** - A hard anodized finish is divided approximately 50% as a coating above the base metal (called “growth”), and 50% penetration below the surface of the part. This principle tends to hold true for most alloys and coating thicknesses.

For example, this means that a .002" coating will add only .001" to each surface of the product.

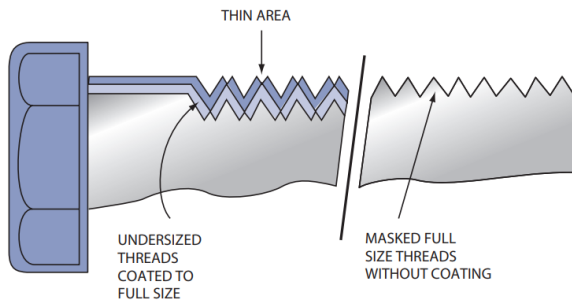

**THREADS** - The build-up on each surface changes the pitch diameter faster than typical two-surface diameters. It may be desirable to machine the threads undersize before anodizing, or mask the thread area before processing.

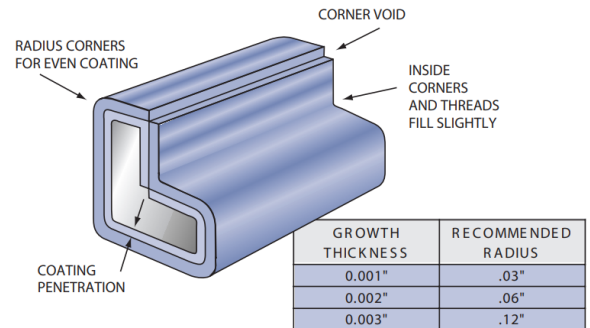

**CORNERS** - Since the coating grows (and penetrates) perpendicular to the surface of the part, sharp corners, both outside and inside, and edges can be a problem. To obtain a uniform coating, they should have a .005" to .050" radius, depending on the anodized thickness desired.

**TOLERANCE** - Precise control can normally be maintained on thickness. Coating thickness can range from .0005" to .0035" as specified. (This is the combined surface and penetration thickness.) Tolerance is normally  $\pm 10\%$  of the total thickness, but not less than  $\pm .0001$ ". Tighter tolerances may be possible through special tooling, or source inspection during processing.

## Ordering Information Required

1. Blueprints are especially helpful for use in masking, and for determining critical areas that should be avoided during the racking process.
2. Coating thickness, and tolerance required. Be sure to specify total thickness and all critical finished dimensions of the part.
3. Type of alloy.
4. Any special handling instructions

NOTE: Direct verbal communication with the Shop Supervisor or Foreman is also advisable.

There are other factors which may affect the application of anodized coatings or the base product after anodizing. Please consult with our technical support staff.